

GNG1103
Design Project User and Product Manual

Submitted by:
Attraction Ambassadors - Group 7
Cyrus Choi, 300344558
Marcus Garcia, 300350558
Avery Poon, 300363244
Johnny Vu, 300360935
Darusan Veerakumar, 300375645
Geu Kenyi, 300397986

April 10, 2024
University of Ottawa

1 Table of Contents

List of Figures	4
List of Tables	5
List of Acronyms and Glossary	6
2 Introduction.....	6
3 Overview.....	6
3.1 Conventions.....	7
3.2 Cautions & Warnings.....	7
4 Getting started.....	7
4.1 Configuration Considerations	7
4.2 User Access Considerations	8
4.3 Accessing/setting up the System.....	8
4.4 System Organization & Navigation	9
4.5 Exiting the System	10
5 Using the System	11
5.1 Clamping System	11
6 Troubleshooting & Support	12
6.1 Error Messages or Behaviors	12
6.2 Special Considerations	13

6.3	Maintenance	15
6.4	Support	16
7	Product Documentation	17
7.1	Subsystem of prototype.....	17
	BOM (Bill of Materials)	17
	Equipment list.....	17
	Instructions.....	17
7.2	Testing & Validation.....	18
7.3	Importance of Design Considerations	19
8	Conclusions and Recommendations for Future Work	19
9	Bibliography	21
	APPENDICES	21
10	APPENDIX I: Design Files	21
11	APPENDIX II: Other Appendices	21

List of Figures

Figure 1. MDCJ Final prototype:

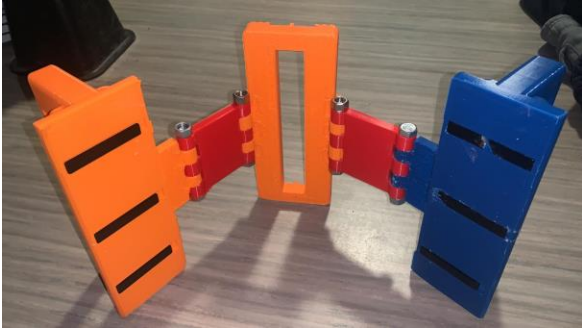

Figure 2. Pictorial version of final prototype:

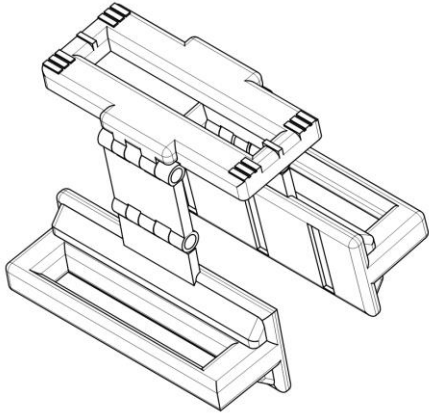

Figure 3. MDCJ main housing:

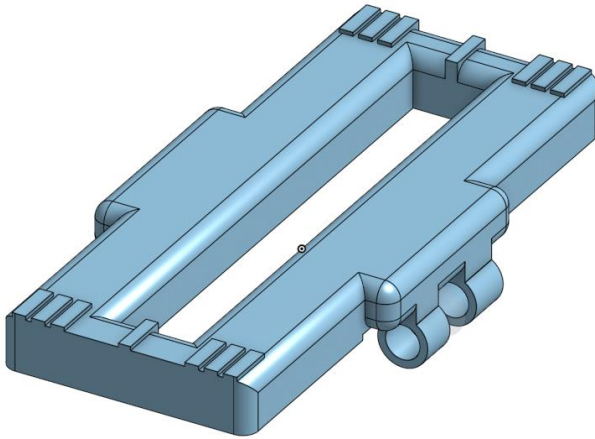
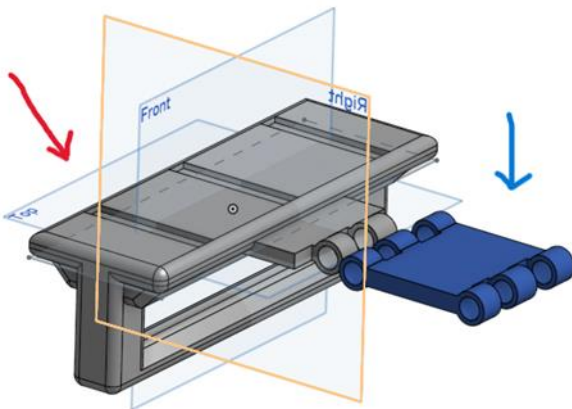

Figure 4. MDCJ magnet holders (indicated by red arrow) and hinges
Indicated by blue arrows:



List of Tables

Table 1. Acronyms.....	vii
Table 2. Glossary	6
Table 3. Referenced Documents	21

List of Acronyms and Glossary

Table 1. Acronyms

Acronym	Definition
UPM	User and Product Manual
MDCJ	Magnetic Door Cutout Jig

2 Introduction

Within the UPM document for the MDCJ developed by the Attraction Ambassadors for the use and production by AMBICO Limited, there will be guided information separated by topic to cover: how to go about the product manufacturing process, the proper usage of the MDCJ, troubleshooting that may occur throughout the products shelf life, product testing before usage, and product documentation.

The primary purpose of the manual is to inform other door manufacturing companies – other than AMBICO Limited – and other individuals who have rightfully gained access to the rights of product production and usage through AMBICO Limited on the proper methods and usage associated with the MDCJ.

Thus, please ensure all users that wish to use, manufacture, or practice any topics covered within the user manual have consulted AMBICO Limited directly and all other person(s) associated with the products usage.

3 Overview

When initially tasked with the problem of trying to develop an adjustable self-centering door jig, to cut out a recessed rectangle so that a metal plate for the strike could be installed, the group underwent numerous design iterations before finalizing on the prototype. The client declared that they needed the jig to have a cutout height of 6-3/4 inches, a width of 1 inch and varying back set based on the thickness of the door. The group's product differentiates from any other group due to the use of magnets. Therefore, instead of a mechanical clamping approach, the group utilizes ferrous properties of the sheet metal backing to safely secure the jig to the door.

Key features:

- 3 neodymium bar magnets on each side of the door

- PLA construction with the utilization of bolts
- Most components are 100% solid plastic

Architecture/Construction:

- Rounded corners to ensure safety
- Lightweight design

Please see **Figures 1 and 2** for images of the final prototype

3.1 Conventions

N/A

3.2 Cautions & Warnings

Before using the prototype, ensure the following Personal Protective Equipment is worn, safety goggles and gloves. Also, empty your pockets of any ferrous/magnetic material as the magnets could damage any electronic device inside its magnetic field. It should be noted that passing a wallet filled with credit or bank cards within this magnetic field carries the risk of data wipe.

In the event of the magnet coming off the jig, cease use immediately and keep the loose magnet away from other metals/magnets to minimize the chances of chipping and breaking.

At all times, keep magnets at least 20 cm away from sensitive electronic and storage devices.

4 Getting started

The MDCJ developed by the Attraction Ambassadors is a simple cutout jig consisting of three main components – the main housing, hinges, and magnet holders – that serve a purpose of accurately routing a flush bolt cutout. In the remaining subsections of section 3, it will be explained how to clearly prepare, assemble, use, and store the MDCJ.

4.1 Configuration Considerations

When using or developing the MDCJ, it is crucial that the model in use or in production contains the three main components:

1. The main housing (**see Figure 3**):
 - i. Used to properly center and route the cutout onto the side of the door
 - ii. Serves as a connection point in between both magnet holders
2. The magnet holders (**see Figure 4**):

- i. Used to connect the neodymium magnets to the rest of the jig
 - ii. Serve as a contact surface between the door and the rest of the jig
 - iii. Are used to allow for the insertion of a handle to the rest of the design
3. The hinges (**see Figure 4**):
 - i. Serve the purpose of making the jig functional across various door widths
 - ii. Connects the main housing to the magnet holders

In addition to having the main three components, the user will also need a ratchet or wrench as additional tools to assemble the components together (only if the user oversees product production).

4.2 User Access Considerations

The only users who should have access and the ability to use the MDCJ are those who have been instructed by AMBICO or any equivalent party to do so and have been demonstrated the proper techniques to safely and correctly use the jig. Typical users with authority of product use include laborers, general contractors, other manufacturing parties who have gained access to the jig's use through the consultation of AMBICO Limited.

4.3 Accessing/setting up the System

For the physical prototype

Preparing the components:

Gather the main housing, hinges, and magnet holders.

Assembling the Components:

1. Attach the hinges to the main housing, ensuring they are securely fastened.
2. Connect the magnet holders to the main housing using the provided screws or fasteners.
3. Insert the neodymium magnets into the magnet holders.

Adjusting for Personal Use (if applicable):

1. Ensure the hinges are positioned to accommodate the width of the door being worked on.
2. Check that the magnets are securely held in place and provide adequate contact with the door surface.

Setting Up the System:

1. Place the MDCJ flush against the side of the door where the flush bolt cutout will be routed.

Securing the System:

1. Use clamps or other methods to secure the MDCJ in place, ensuring it remains steady during the routing process.

Testing and Adjustment:

1. Before routing the cutout, double-check the alignment and stability of the MDCJ. Make any necessary adjustments to ensure accurate and precise routing.

4.4 System Organization & Navigation

This is a general description of the organization of the MDCJ physical prototype:

Main Housing:

The main housing serves as the central component of the MDCJ system. It is designed to properly center and route the cutout onto the side of the door. The main housing also acts as a connection point between both magnet holders. It typically consists of a sturdy frame or body with precision-cut channels or guides to ensure accurate routing.

Magnet Holders:

The magnet holders are essential components that connect the neodymium magnets to the rest of the jig. They serve as a contact surface between the door and the rest of the jig, ensuring stability and proper alignment during the routing process. Additionally, the magnet holders allow for the insertion of a handle to the rest of the design, facilitating ease of use and manipulation.

Hinges:

The hinges play a crucial role in making the jig functional across various door widths. They connect the main housing to the magnet holders, providing flexibility and adjustability to accommodate doors of different sizes. The hinges allow the MDCJ to pivot and adjust its position relative to the door, ensuring proper alignment and stability during use.

Connections:

The main features of the MDCJ system are linked together through a combination of screws, bolts, or fasteners, depending on the design. The hinges are typically attached to the main housing using screws or bolts, providing a sturdy connection that allows for smooth pivoting and adjustment. Similarly, the magnet holders are secured to the main housing using screws or fasteners, ensuring

they remain firmly in place during use. Additionally, the neodymium magnets are inserted into the magnet holders, creating a strong magnetic connection between the MDCJ and the door surface. Here's a general description of the organization of the MDCJ software prototype:

4.5 Exiting the System

To properly put away the physical MDCJ system:

Clean Up Workspace:

Begin by cleaning up the workspace around the MDCJ system. Remove any debris, tools, or materials that may have accumulated during use to ensure a tidy and safe environment.

Disassemble Components:

Carefully disassemble the various components of the MDCJ system. Start by removing any clamps or securing devices used to hold the system in place during operation.

Separate Parts:

Separate the main housing, hinges, magnet holders, and any other accessories or attachments used during the routing process. Take care to keep track of all components to prevent loss or damage.

Inspect for Damage:

Before storing the components, inspect each part for any signs of damage or wear. Check for cracks, loose fasteners, or other issues that may affect the performance of the system.

Clean and Maintain:

Clean each component of the MDCJ system using a damp cloth or mild cleaning solution as needed. Remove any dirt, dust, or debris that may have accumulated during use to maintain optimal performance and prolong the lifespan of the system.

Organize and Store:

Once cleaned and inspected, organize the components of the MDCJ system for storage. Store each part in a designated area or container to prevent misplacement or damage.

Secure Storage: Store the MDCJ system in a secure location away from potential hazards such as moisture, extreme temperatures, or heavy objects. Use protective covers or cases if available to further safeguard the components during storage.

Label (Optional):

Consider labeling the storage containers or compartments to easily identify the components of the MDCJ system for future use. This can help streamline the setup process and prevent confusion when reassembling the system.

5 Using the System

The following sub-sections provide detailed, step-by-step instructions on how to use the various functions or features of the MDCJ.

5.1 Clamping System

The MDCJ, also known as the Magnetic Door Cutout Jig, uses magnets as the clamping system. As the doors used by AMBICO will have an inner lining of metal, our jig leverages this as our approach. Magnets in general are intuitive to use and our system is no different. Our clamping system consists of neodymium magnets as they are strong enough to tightly clamp metal through wood thicker than AMBICO's. To use the clamping system, first attach each handle to each respective side of the door like shown in figure 5. You must make sure to attach it so the top housing of the jig is flushed on the door. This is to ensure that it will be aligned accurately. To remove the jig, simply pull off each handle.



Figure 5: MDCJ's magnetic clamping system attached and flush with the door

5.2 Centering System

To accurately align and center the jig, align the sides of the door to the markings on the top housing of the jigs as shown in figure 6. Note that if the top housing is not flush with the door, the centering will not be accurate.



Figure 6: MDCJ properly centered using markings on top housing

6 Troubleshooting & Support

This section will show you what you need to do when you encounter a problem and if you can't fix it on your own. We will show you where you can find assistance and guidance to users or customers helping them resolve issues, understand features, and use products or services effectively.

6.1 Error Messages or Behaviors

Misalignment:

If the jig is not properly aligned with the door edge or surface, it might lead to hardware being installed off-center or at an incorrect angle. This can result in a door that does not close or open smoothly or hardware that appears skewed.

Incorrect Size or Type:

Jigs come in various sizes and configurations to match different types of doors and hardware. Using the wrong jig can lead to errors in placement or size, meaning the hardware won't fit properly.

Inadequate Clamping:

If the jig is not securely clamped to the door, it might move during use, leading to inaccurate drill holes or hardware placement.

Drill Bit Issues:

Using a dull or incorrect size drill bit with the jig can result in poor quality holes, which may not properly accommodate the hardware. It can also lead to splintering or damage to the door.

Material Compatibility:

Some jigs are designed for specific door materials (wood, metal, etc.). Using a jig on an incompatible door material might result in damage to the door or ineffective installation.

Wear and Tear:

Over time and with extensive use, a jig can wear out or become damaged, which might lead to inaccurate placement or the inability to secure the jig properly.

User Error:

Improper setup or use of the jig, such as not following the manufacturer's instructions, can lead to mistakes in hardware installation.

6.2 Special Considerations

Purpose and Specificity:

Determine the specific tasks the jig needs to perform, such as hinge placement, lockset installation, or drilling pilot holes. The design should cater specifically to these tasks with precision.

Material Selection:

The materials used for the jig should be durable and suitable for repeated use. Common choices include hardwoods for manual jigs and metals or high-density plastics for more industrial applications.

Adjustability:

A good door jig should be adjustable to accommodate doors of different sizes and thicknesses. This adjustability ensures the jig can be used across various projects without the need for multiple, task-specific jigs.

Clamping Mechanism:

The jig should have a reliable and easy-to-use clamping mechanism to securely attach it to the door. This feature is crucial for stability and precision during the work process.

Accuracy and Precision:

High precision is vital, especially for tasks like hinge mortising or lockset installation. The jig should have clear, accurate markings and should maintain its settings reliably during use.

Ease of Use:

The design should be user-friendly, allowing for quick setup, adjustment, and operation, even for users with limited experience. It should also be easy to remove without damaging the door.

Safety:

Incorporate features that enhance safety, such as secure grips and shields to protect the user from cutting tools and sawdust.

Portability and Storage:

Especially for on-site jobs, the jig should be lightweight and compact for easy transportation and storage.

Compatibility with Tools:

Ensure the jig is compatible with the tools you plan to use, such as routers, drills, or chisels. The design should facilitate easy access for these tools while maintaining safety and accuracy.

Maintenance and Durability:

The jig should be easy to clean and maintain, resistant to wear and tear, and durable enough to withstand the rigors of repeated use.

6.3 Maintenance

Clean Regularly:

After each use, clean the jig thoroughly to remove sawdust, debris, or any adhesive that might have come into contact with it. A clean jig is essential for accurate placement and protection from wear.

Inspect for Wear and Damage:

Regularly inspect the jig for signs of wear, damage, or any deformities. Pay special attention to any areas that come into direct contact with tools or the workpiece, as these are most susceptible to wear.

Lubricate Moving Parts:

If your jig has any moving parts, ensure they are lubricated according to the manufacturer's recommendations. Proper lubrication prevents rust and ensures that the components move smoothly.

Check for Accuracy:

Periodically, it's important to check the jig for accuracy. You can do this by using the jig to mark a test piece and then measuring the results. If the jig is off, you may need to adjust it or replace certain components.

Store Properly:

When not in use, store the jig in a dry, dust-free environment to prevent rust and corrosion. Avoid hanging or placing heavy objects on top of the jig, as this could deform or damage it.

Tighten Fasteners:

Regularly check and tighten any screws, bolts, or fasteners. Loose components can affect the jig's precision and lead to inaccuracies in your work.

Replace Consumable Parts:

Some jigs have parts that are meant to be replaced periodically, such as guide bushings or drill bits. Check these components regularly and replace them as necessary to maintain the jig's performance.

Refer to the Manufacturer's Instructions:

Always refer to the maintenance instructions provided by the manufacturer, as they may have specific recommendations for your particular model.

Professional Servicing:

If you notice any significant issues or if the jig requires adjustments beyond your expertise, consider getting it serviced by a professional.

6.4 Support

In case of emergencies or the need for system support, users can reach out to our dedicated support team for prompt assistance. Our support services include help desk support and production support to ensure smooth operation and resolution of any issues encountered.

Help Desk Support:

- **Responsible Person:** Avery Poon
- **Email Address:** apoon050@uottawa.ca

Production Support:

- **Responsible Person:** Johnny Vu
- **Email Address:** jvu021@uottawa.ca

Reporting System Problems:

If users identify any problems or issues with the system, they should follow these steps to report them effectively.

Document the Issue:

The problem includes any error messages or unusual behaviour observed.

Contact Support:

Use the provided email addresses to email the help desk or production support team, including a detailed description of the issue and any relevant screenshots or logs.

Priority Level:

Specify the urgency or priority level of the issue based on its impact on system functionality or operations.

7 Product Documentation

7.1 Subsystem of prototype

BOM (Bill of Materials)

Subtotal	47.98	Total	54.22		
Quantity	Price (\$)	Quantity *Price	Item	Notes	Link
1	0.00	0.00	Onshape Software	N/A	link
2	5.00	10.00	PLA Filament (1 roll)	Provided to us through Makerspace	link
1	13.99	13.99	Neodymium Bar Magnets (Pack of 6)	Ordered through Amazon	link
4	\$5.00	20.00	1 set of bolts/nuts/washers	Sourced through Marcus Garcia	N/A
1	3.99	3.99	Super Glue	To adhere magnets to PLA Sourced through Cyrus Choi	link

Equipment list

- 3D Printer
 - Super Glue
 - Screwdriver
 - Wrench
 - Computer (for on shape)

Instructions

1. Design Considerations and Calculations:

Before starting the build, we considered various factors such as magnet strength, housing design for optimal clamping force, and material compatibility. Calculations were done using MATLAB to predict magnet strength outcomes based on distance and magnetic flux.

2. Printing the Housing:

Use OnShape software to design the housing components according to the specified dimensions (6-3/4" height, 1" width, accommodating any backset length). Ensure the design

allows for easy integration of magnets and structural reinforcement with bolts/nuts/washers. Print the housing using PLA filament with 100% infill for maximum strength.

3. Attaching Magnets:

Apply super glue to securely attach neodymium bar magnets to the designated areas inside the housing. Follow the numerical modelling predictions to position the magnets for optimal magnetic flux and clamping force.

7.2 Testing & Validation

Magnet Strength Test:

Measure the magnetic force at different distances to confirm alignment with numerical modelling predictions.

Clamping Force Test:

Clamp onto various surfaces and measure the force required to detach, ensuring it meets the specified clamping requirements.

Magnet Strength Test Data:

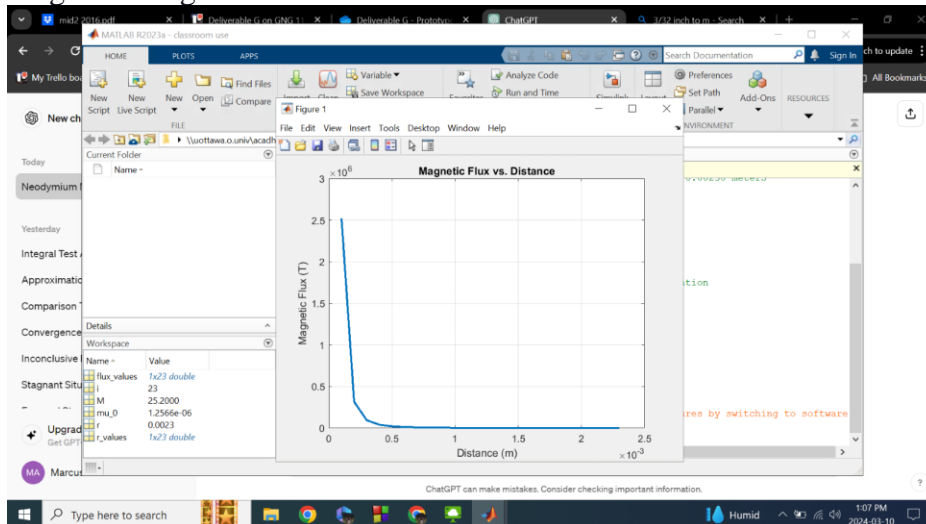

Clamping Force Test Results:



7.3 Importance of Design Considerations

Material Choice:

PLA filament was chosen for its balance of strength and affordability. Alternative materials like ABS were considered but deemed less suitable due to cost or printing challenges.

Magnet Selection:

Neodymium magnets were selected for their superior strength compared to electromagnets. Testing confirmed their ability to hold securely through various materials.

Reinforcement with Bolts:

Using metal bolts/nuts/washers instead of 3D printed components improved structural integrity, addressing previous weaknesses identified in testing.

8 Conclusions and Recommendations for Future Work

Lessons Learned:

Material Selection:

Our choice of PLA filament and neodymium magnets effectively balanced strength, affordability, and performance. However, alternative materials and magnet configurations could be explored for specific use cases.

Design Iteration:

Iterative prototyping and testing helped identify weaknesses and areas for improvement, such as structural integrity and clamping force.

User Feedback:

Incorporating user feedback, especially regarding colour coordination and handling, significantly improved the overall user experience.

Numerical Modeling:

Numerical modelling tools like MATLAB provide valuable insights into magnet strength predictions, aiding design optimization.

Recommendations for Future Work:**Cost-Effective Material Exploration:**

Investigate alternative materials within the budget, such as reinforced plastics or aluminum alloys, to enhance durability and temperature resistance without exceeding the cost constraints.

Optimized Magnet Configuration:

Experiment with different magnet configurations using the existing neodymium magnets to achieve more robust and versatile clamping capabilities without additional cost.

DIY Structural Reinforcement:

Explore DIY solutions for reinforcing the housing structure, such as adding additional layers of PLA or integrating small metal inserts strategically to improve structural integrity within budgetary limits.

User Feedback Integration:

Continue to gather and incorporate user feedback into design iterations, focusing on improvements that align with user needs while remaining mindful of cost implications.

If Given More Time:**Advanced Material Testing:**

Conduct comprehensive material testing within the budget to evaluate alternative materials' long-term durability, corrosion resistance, and environmental sustainability.

Detailed Magnet Optimization:

Invest time in detailed simulations and physical tests to optimize the placement and orientation of magnets for maximum clamping force and efficiency without additional cost.

DIY Smart System Integration:

Explore DIY solutions or open-source platforms for cost-effectively integrating smart features like sensor monitoring and control mechanisms.

Market Research Validation:

Conduct cost-effective market research and user surveys using free or low-cost tools to validate the prototype's market potential and gather actionable insights for future enhancements.

9 Bibliography

Depot, H. (2023, January 22). Ryobi door hinge template. RYOBI Door Hinge Template. <https://www.homedepot.ca/product/ryobi-door-hinge-template/1000732628>

Tool, M. (n.d.). Hole Dozer Door Lock Installation Hole saw kit: Milwaukee tool. HOLE DOZERTM Door Lock Installation Hole Saw Kit. <https://www.milwaukeetool.ca/Products/49-22-4073>

APPENDICES

10 APPENDIX I: Design Files

Table 2. Referenced Documents

Document Name	Document Location and/or URL	Issuance Date
Deliverable G	https://uottawa-my.sharepoint.com	March 6, 2024
Client Meet 2	https://cyruschoisy.github.io/attrac	March 5, 2024
Client Meet 3	https://cyruschoisy.github.io/attrac	March 20, 2024
Final Class Presentation	https://cyruschoisy.github.io/attrac	March 24, 2024
Design Day Flyer	https://cyruschoisy.github.io/attrac	April 2, 2024
Maker Repo Page	https://makerepo.com/MarcusGarcia	Feb 27, 2024
Project Proposal	https://makerepo.com/project_prop	Jan 9, 2024
Design Day Presentation	https://cyruschoisy.github.io/attrac	April 1, 2024

11 APPENDIX II: Other Appendices

Our website contains all the work done for the project:

<https://cyruschoisy.github.io/attraction-ambassadors/index.html>

